



StreamStor
Real-time Disk Controller
Models PCI-816XF2, PCI-816XF

Installation and User Manual

Copyright and Trademarks

The information in this document is subject to change without notice.

This document contains proprietary information that is protected by copyright. All rights are reserved. No part of this document may be photocopied, reproduced, or translated to another language without the prior written consent of Conduant Corporation.

Printed in the United States.

© 2006 Conduant Corporation. All rights reserved.

StreamStor is a trademark of Conduant Corporation.

All other trademarks are the property of their respective owners.

Version: 7.7

Publication date: May 24, 2006

TABLE OF CONTENTS

LICENSE AGREEMENT AND LIMITED WARRANTY 4

ABOUT THIS MANUAL 6

ABOUT THE REAL-TIME STORAGE CONTROLLER..... 7

COMPONENTS 9

UNPACKING / HANDLING 10

 DISK DRIVES 10

 STREAMSTOR BOARD 10

HARDWARE INSTALLATION 11

 CONTROLLER CARD 12

 DRIVE CONFIGURATION 13

 INSTALLING THE DRIVES 14

 CONNECTING INTERFACE AND POWER CABLES 14

 DRIVE AUTO CONFIGURATION 15

SOFTWARE INSTALLATION..... 16

SOFTWARE FUNCTIONALITY 17

FPDP PORTS 19

 INTERFACE ELECTRONICS 19

 DATA FORMATS 19

 PIO SIGNALS 20

 CONNECTOR POSITION 20

 INTERFACE FUNCTIONS 20

 PSTROBE/PSTROBE* AND STROB SIGNALS 21

 OPERATING FREQUENCY RANGE 22

PROGRAMMING..... 22

TECHNICAL SUPPORT 26

 CONTACTING TECHNICAL SUPPORT 27

License Agreement and Limited Warranty

IMPORTANT: CAREFULLY READ THE TERMS AND CONDITIONS OF THIS AGREEMENT BEFORE USING THE PRODUCT. By installing or otherwise using the StreamStor Product, you agree to be bound by the terms of this Agreement. If you do not agree to the terms of this Agreement, do not install or use the StreamStor Product and return it to Conduant Corporation.

GRANT OF LICENSE. In consideration for your purchase of the StreamStor Product, Conduant Corporation hereby grants you a limited, non-exclusive, revocable license to use the software and firmware which controls the StreamStor Product (hereinafter the "Software") solely as part of and in connection with your use of the StreamStor Product. If you are authorized to resell the StreamStor Product, Conduant Corporation hereby grants you a limited non-exclusive license to transfer the Software only in conjunction with a sale or transfer by you of the StreamStor Product controlled by the Software, provided you retain no copies of the Software and the recipient agrees to be bound by the terms of this Agreement and you comply with the RESALE provision herein.

NO REVERSE ENGINEERING. You may not cause or permit, and must take all appropriate and reasonable steps necessary to prevent, the reverse engineering, decompilation, reverse assembly, modification, reconfiguration or creation of derivative works of the Software, in whole or in part.

OWNERSHIP. The Software is a proprietary product of Conduant Corporation which retains all title, rights and interest in and to the Software, including, but not limited to, all copyrights, trademarks, trade secrets, know-how and other proprietary information included or embodied in the Software. The Software is protected by national copyright laws and international copyright treaties.

TERM. This Agreement is effective from the date of receipt of the StreamStor Product and the Software. This Agreement will terminate automatically at any time, without prior notice to you, if you fail to comply with any of the provisions hereunder. Upon termination of this Agreement for any reason, you must return the StreamStor Product and Software in your possession or control to Conduant Corporation.

LIMITED WARRANTY. This Limited Warranty is void if failure of the StreamStor Product or the Software is due to accident, abuse or misuse.

Hardware: Conduant's terms of warranty on all manufactured products is one year from the date of shipment from our offices. After the warranty period, product support and repairs are available on a fee paid basis. Warranty on all third party materials sold through Conduant, such as chassis, disk drives, PCs, bus extenders, and drive carriers, is passed through with the original manufacturer's warranty. Conduant will provide no charge service for 90 days to replace or handle repair returns on third party materials. Any charges imposed by the original manufacturer will be passed through to the customer. After 90 days, Conduant will handle returns on third party material on a time and materials basis.

Software: The warranty on all software products is 90 days from the date of shipment from Conduant's offices. After 90 days, Conduant will provide product support and upgrades on a fee paid basis. Warranties on all third party software are passed through with the original manufacturer's warranty. Conduant will provide no charge service for 90 days to replace or handle repair returns on third party software. Any charges imposed by the manufacturer will be passed through to the customer.

DISCLAIMER OF WARRANTIES. TO THE MAXIMUM EXTENT PERMITTED BY APPLICABLE LAW, CONDUANT CORPORATION DISCLAIMS ALL OTHER WARRANTIES AND CONDITIONS, EITHER EXPRESS OR IMPLIED, INCLUDING, BUT NOT LIMITED TO, IMPLIED WARRANTIES OF MERCHANTABILITY, FITNESS FOR A PARTICULAR PURPOSE, TITLE, AND NONINFRINGEMENT, WITH REGARD TO THE STREAMSTOR PRODUCT AND THE SOFTWARE.

SOLE REMEDIES. If the StreamStor Product or the Software do not meet Conduant Corporation's Limited Warranty and you return the StreamStor Product and the Software to Conduant Corporation, Conduant Corporation's entire liability and your exclusive remedy shall be at Conduant Corporation's option, either (a) return of the price paid, if any, or (b) repair or replacement of the StreamStor Product or the Software. Any replacement Product or Software will be warranted for the remainder of the original warranty period.

LIMITATION OF LIABILITIES. TO THE MAXIMUM EXTENT PERMITTED BY APPLICABLE LAW, IN NO EVENT SHALL CONDUANT CORPORATION BE LIABLE FOR ANY SPECIAL, INCIDENTAL, INDIRECT OR CONSEQUENTIAL DAMAGES WHATSOEVER (INCLUDING, WITHOUT LIMITATION, DAMAGES FOR LOSS OF BUSINESS PROFITS, BUSINESS INTERRUPTION, LOSS OF BUSINESS INFORMATION, OR ANY OTHER PECUNIARY LOSS) ARISING OUT OF THE USE OF OR INABILITY TO USE THE STREAMSTOR PRODUCT AND THE SOFTWARE. IN ANY CASE, CONDUANT CORPORATION'S ENTIRE LIABILITY UNDER ANY PROVISION OF THIS AGREEMENT SHALL BE LIMITED TO THE AMOUNT ACTUALLY PAID BY YOU FOR THE STREAMSTOR PRODUCT AND THE SOFTWARE. BECAUSE SOME STATES AND JURISDICTIONS DO NOT ALLOW THE EXCLUSION OR LIMITATION OF LIABILITY, THE ABOVE LIMITATION MAY NOT APPLY TO YOU.

RESALE. If you are authorized to resell the StreamStor Product, you must distribute the StreamStor Product only in conjunction with and as part of your product that is designed, developed and tested to operate with and add significant functionality to the StreamStor Product; you may not permit further distribution or transfer of the StreamStor Product by your end-user customer; you must agree to indemnify, hold harmless and defend Conduant Corporation from and against any claims or lawsuits, including attorneys' fees, that arise or result from the use or distribution of your product; and you may not use Conduant Corporation's name, logos or trademarks to market your product without the prior written consent of Conduant Corporation.

ENTIRE AGREEMENT; SEVERABILITY. This Agreement constitutes the complete and exclusive agreement between you and Conduant Corporation with respect to the subject matter hereof and supersedes all prior written or oral agreements, understandings or communications. If any provision of this Agreement is deemed invalid under any applicable law, it shall be deemed modified or omitted to the extent necessary to comply with such law and the remainder of this Agreement shall remain in full force and effect.

GOVERNING LAW. This Agreement is governed by the laws of the State of Colorado, without giving effect to the choice of law provisions therein. By accepting this Agreement, you hereby consent to the exclusive jurisdiction of the state and federal courts sitting in the State of Colorado.

About This Manual

This manual is intended to serve the following purposes:

- * to provide an overview of the StreamStor Real-Time Storage Controller models PCI-816XF2 and PCI-816XF.
- * to act as a guide for hardware installation
- * to act as a reference for the operator
- * to provide guidance on software capabilities and choices

It is suggested that you periodically check the Conduant web site for the most recent software updates, application notes, and technical bulletins.

If you are unable to locate the information you need, please feel free to contact us by e-mail or phone.

About the Real-Time Storage Controller

Thank you for purchasing a StreamStor Real-Time Storage System. Your StreamStor system is a disk-based, real-time recording system for PCI bus computers. The StreamStor system consists of a controller card that plugs into the PCI bus, high performance disk drives, device drivers, software development tools, and additional utility software.

The PCI bus is a high performance I/O bus designed for attaching peripheral devices to computer systems. It is found in computing systems from many different manufacturers and is supported by most major operating systems. By utilizing the PCI bus instead of a proprietary bus interface, StreamStor provides an open platform recording system. PCI data acquisition cards (digital oscilloscopes, frame grabbers, telemetry interfaces, etc) are available from many manufacturers to collect data and record it to system memory in real time (as it is collected). StreamStor provides a large capacity and cost effective alternative to system memory for these applications.

The StreamStor Storage System is able to receive data over the PCI bus directly from the data acquisition device at very high average (sustained) data rates. Virtually all of the available PCI cards that can record data to system memory are compatible with StreamStor. Only minor software modifications are generally required to redirect data to the StreamStor PCI card. This capability is often in the software provided by the manufacturers of data acquisition devices. Conduant maintains a list of tested configurations, please contact technical support for more information.

StreamStor was specifically designed to record sequential data without interruption at very high data rates. This is in contrast to traditional storage systems that are designed for data processing purposes and cannot sustain these high data rates. Unlike typical computer disk storage solutions that are designed for optimum performance during random data reads and writes, StreamStor has been designed for optimum performance in sequential read and write operations. The StreamStor system has also been designed to operate without host computer intervention. This eliminates any bottlenecks or interruptions in the data stream due to heavy computer loads or delays.

The StreamStor PCI-816XF2 card includes dual FPDP external data interfaces. These interfaces move data to/from the board at very high data rates with very little overhead. This provides a seamless method of interfacing to external data interfaces for high performance recording.

The StreamStor SDK includes the device drivers and API (Application Programming Interface) to provide a smooth integration of StreamStor with the data acquisition device and/or analysis software. Many examples are provided with the SDK and more are available upon request.

The StreamStor system is a flexible and powerful platform for high performance recording applications. Many custom and unique capabilities are available that are beyond the scope of this documentation so please contact Conduant with your questions and special requirements.

Components

A StreamStor real-time storage system generally consists of the following components:

- StreamStor board
- Disk drives
- Cables
- Software Development Kit
- User Manual(s)

Some systems are delivered from Conduant completely installed in a chassis with a PC motherboard and operating system. You can skip the installation section for these systems since all installation has been performed at the factory.

 **CAUTION:** *Please read the entire installation section before starting to install the hardware. This manual assumes that the user is knowledgeable and comfortable with basic computer work, including installation and safety considerations. If you are unsure as to how to proceed, please contact Conduant support.*

Unpacking / Handling

Carefully inspect all shipping packages for any sign of damage. In particular, look for wrinkled or bent corners, holes, or other signs of bad handling or abuse. If you notice any damage to the packaging, immediately open the boxes and inspect the contents for damage. Pay close attention to the components near the area where the packing material was damaged. Report any damage to the carrier and Conduant immediately.

Disk Drives

Hard disk drives such as those that have been included with your system are susceptible to damage from excess shock and careless handling. Please observe the following handling precautions:

- * Allow the disk drives to reach room temperature BEFORE installation. This may take several hours depending on shipping conditions. Disk drive damage can occur if the system is powered while the drives are at temperature extremes.
- * Do not drop, jar or bump the disk drives. Even setting the chassis on a hard surface too roughly can damage the recording surfaces, heads, or other mechanical components inside the disk drives.
- * Never disconnect/connect the interface cable while power is on
- * Always use precautions to prevent electrostatic discharge while handling the disk drive.

The disk drives must be installed according to the manufacturer's instructions. Please check the manufacturer's website for the latest installation information.

StreamStor Board

The StreamStor controller board is shipped in a specially designed antistatic box or bag to prevent electrostatic damage to the board. To avoid damage in handling the board, take the following precautions:

- * Ground yourself with a grounding strap or grasp a conductive, grounded object to dissipate any static charge while handling the board.
- * Always store the board in its antistatic package when not installed in a computer system.
- * Inspect the board carefully before installing in the computer. Do not install a damaged board into your computer.
- * Never touch any exposed connector pins or component leads.
- * Avoid bending or twisting the board.

Hardware Installation

The StreamStor controller board uses anywhere from 1 to 8 Ultra ATA interface cables (depending on the configuration) to connect the controller to up to 16 disk drives. Not all computer chassis layouts easily facilitate this type of cabling. The configuration and layout of the computer chassis will greatly affect the ease of installing the StreamStor system. Contact Conduant if you need help in choosing or designing an appropriate chassis. Extension chassis systems are also available to avoid impacting an existing computer system.

The controller board can utilize the following combinations of disk drives: 1, 2, 3, 4, 5, 6, 7, 8, 10, 12, 14 or 16. Each interface cable should have one or two drives attached. (see Drive Configuration below). The cables supplied by Conduant will allow the drives to self configure as the Master or Slave device on the cable. The disk drive must be configured for "Cable Select" mode for this to work properly. If you are not using the cable select mode of configuration you must insure that there is at least one master if one drive is on the cable and one master and one slave if two drives are on the cable. If there is only a single drive on the interface cable, always attach the drive to the end connector which should be color coded black. The blue connector end should always attach to the StreamStor card. Prior to mounting anything in the chassis, place the disk drives and the StreamStor card on a flat, static free surface and model the routing and placement of the cables. Pay close attention to the connector keys because these may define which way the disk drives must be mounted. Avoid pinching or routing over sharp edges to prevent cable damage.

The orientation of the disk drives can greatly affect the ease of cable routing. In horizontal orientations, mounting the drive with the board facing down prevents debris from inadvertently damaging or shorting the electronics and is the preferred orientation. Generally, all drives should be mounted in the same orientation to avoid twists in the cables.

⚠ CAUTION: *When removing cables from the StreamStor board, ALWAYS use the ejector tabs to gently free the cables from the board. NEVER pull on the cables to free them from the board.*

The cables supplied with your system are the maximum recommended length (24"). Avoid the use of longer cables since they may cause intermittent data loss. Removable drive carriers add several connections to the interface bus that can also cause intermittent data problems. Several removable drive carriers are known to work with StreamStor, please contact Conduant if you have special requirements for them.

All StreamStor models are upgradeable for increased storage capacity and high sustained data rates. Please contact Conduant for more information on upgrades.

Controller Card

The StreamStor controller is a universal PCI card that meets the PCI 2.1 specification (figure 1). Installation requires a PCI slot that can accommodate a full size card and has a card support guide. Clearance is also required for the drive cables exiting from the controller card. The card can be used in PCI slots supporting 32 or 64 bits and 33 or 66 MHz. For maximum performance the card should be inserted into a 64 bit PCI slot. Consult your system documentation for more information. An illustration of the card is shown in Figure 1.

Model	Drive Buses	Drive Cables	Drives
PCI-816XF (one external port)	8	8	16
PCI-816XF2 (two external ports)	8	8	16

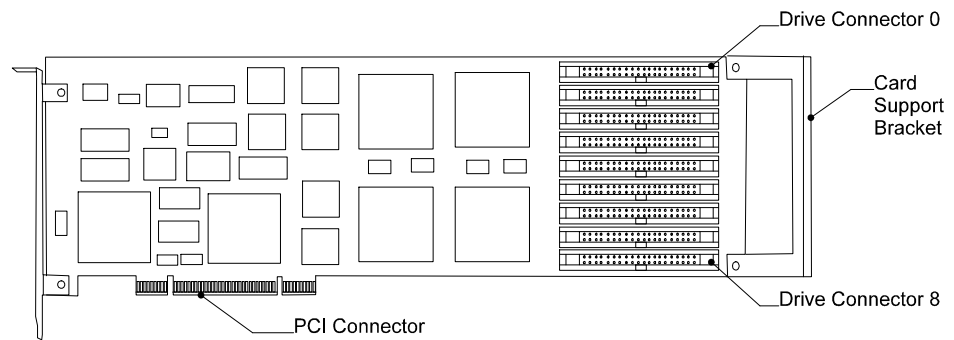

Figure 1 - StreamStor PCI-816XF2 and PCI-816XF Controller Card

When connecting drives to the board please you should always use the connectors in order from 0 to 7. Table 2 details the drive numbering scheme used by the StreamStor software.

Connector #	Master	Slave
0	0	1
1	2	3
2	4	5
3	6	7
4	8	9
5	10	11
6	12	13
7	14	15

The following are general instructions for installing your StreamStor controller. You should also consult your computer user manual or technical reference for more specific instructions and warnings.

⚠ CAUTION: *Over-flexing the circuit board will damage the controller.*

📌 NOTE: *You may find it easier to attach the drive interface cables BEFORE installing the controller board. Be careful to prevent damage to any components on the backside of the circuit board if you lay the card down.*

1. Turn off and unplug your computer.
2. Remove the top cover or access port to the I/O bus.
3. Remove the expansion slot cover on the back panel of the computer for the slot into which you intend to install the StreamStor controller.
4. Insert the StreamStor controller board into the chosen PCI slot. Gently rock the board to ease it into place. It may be a tight fit but do not force the board into place. Make sure that the card support bracket lines up correctly with the support provided in the computer chassis.
5. Screw the mounting bracket to the back panel of the computer chassis.
6. Proceed to drive installation and cabling.

Drive Configuration

The StreamStor controller and drives must be attached using Ultra ATA cables. An Ultra ATA cable has 80 wires and 40-pin connectors at each end with an optional 3rd connector between the ends. The cables have a blue, black (master) and a gray connector (slave), or only a blue and a black connector. The blue connector is the host connector and should always attach to the StreamStor card.

All Ultra ATA cables (80-conductor) support the cable select feature. This feature eliminates the need to set the master and slave jumpers on each drive. The drive jumpers must be configured for cable select. Drives shipped from Conduant will be preconfigured to use cable select.

If you need to configure your system to use cable select, set the drive address jumper to "Cable Select." The drive then uses the cable to determine if it is a master or a slave. The drive that is attached to the master connector (black) will automatically set itself to operate as a master (device 0). The drive that is attached to the slave connector (gray) will automatically set itself to operate as a slave (device 1).

The black connector (which is on the end of the cable) is the master connector. The gray connector (which is the middle of the cable) is the slave connector.

Note that if there is only one drive on a cable, it must be attached to the black connector.

When adjusting jumpers, it is recommended that the user look at the jumper guide that is usually printed on the drive. If there is no such guide, the user should refer to other shipped material, the web site of the disk drive manufacturer, or contact Conduant for assistance.

NOTE: *If any drive cable has 2 drives (Master + Slave) then all cables in use must have 2 drives for proper operation of the StreamStor controller.*

Be careful to match the connector keys when connecting the drive to the cable and never force the connection, as this could damage the disk drive.

Installing the Drives

The method used to mount the disk drives is left to you. There are many brackets available to adapt different disk drives into the chassis, please contact Conduant for more information. Be sure to follow the handling precautions described above in the unpacking/handling section when installing the hard drives.

Connecting Interface and Power Cables

Depending on the orientation you chose for the disk drives, you may find it easier to first attach the drive power cables or the drive interface cables. You should first attach whichever connectors are furthest from your reach. Be careful to support the StreamStor PCI card when plugging in the drive cables to avoid over flexing the circuit board. Also, be careful to correctly orient the connector since they are all keyed to prevent incorrect insertion.

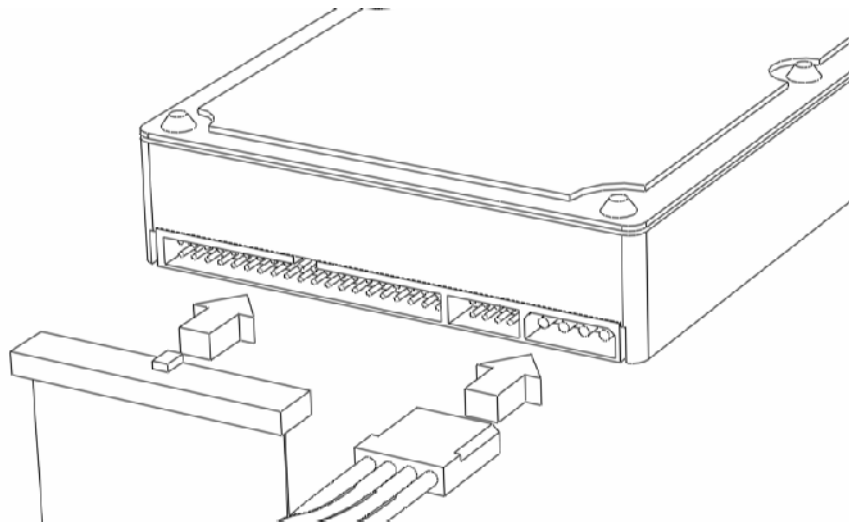

Figure 1 - ATA Drive

⚠ CAUTION: *The signal and power connectors are keyed to prevent incorrect insertion. Exerting excessive force with the connectors improperly aligned can cause damage. Even with the correct alignment, care should be taken to not apply excessive force or torque.*

Carefully connect and route the interface cables from the StreamStor controller to the disk drives. Remember that either all cables must have a MASTER drive only or both a MASTER and SLAVE drive. There is no requirement to attach the cables to a particular connector on the controller board for a new installation but they must be used in order starting at connector zero

Drive auto configuration

The StreamStor controller boards support auto configuration to the number of drives installed. The PCI-816XF, PCI-816XF2, PCI-816V100, and PCI-816VXF2 boards can support 1,2,3,4,5,6,7,8,10,12,14 and 16 drive configurations. If any drive cable has a slave drive then all cables must have a slave drive. Connectors on the controller board should be used in order without gaps starting from connector zero (0). You should always check that all drives are being recognized by the system using the `XLRGetDeviceInfo` function call. The `sscfcfg.exe` program also reports this information after initialization.

Software Installation

Your StreamStor system was shipped with the Software Development Kit on CD-ROM. Install the software prior to installing the hardware if possible. On Windows systems, when ready, run the `setup.exe` program on the CD-ROM to start the installation process. On Linux systems, refer to the installation text file "`linux/docs/install.txt`" on the CD-ROM.

Plug and play operating systems such as Windows will detect the installation of the StreamStor board and attempt to configure the boards using the hardware plug and play wizard program. The required installation information file for plug and play installation is included on the CD-ROM. Make sure the plug and play wizard includes the CD-ROM drive in its search so that the StreamStor drivers will be properly installed. You should not cancel the plug and play wizard since this can create hardware conflicts in the system when using the StreamStor controller. Note that the `setup.exe` program must still be executed to install the StreamStor SDK onto your system.

The software installation procedure will install the device drivers, library files, example programs and all other components of the SDK onto your system.

The StreamStor SDK does not include software interfaces or drivers used for the control of data acquisition cards made by other manufacturers. However, it does include some sample programs to help in your software development efforts. Other drivers and examples may be available depending on your choice of data acquisition hardware. Contact Conduant support for more information.

Always review the `readme.htm` file included with the SDK for the latest information not included in this manual. Also, check the Conduant web site periodically for additional information.

Software Functionality

The StreamStor controller supports recording and playback (or read) from the PCI bus or FPDP interface at up to 200 MB/s. The following API commands are supported by your controller:

- XLRApiVersion
- XLRAppend
- XLRArmFPDP
- XLRBindInputChannel
- XLRBindOutputChannel
- XLRCardReset
- XLRClearChannels
- XLRClearOption
- XLRClearWriteProtect
- XLRClose
- XLRDeleteAppend
- XLRDeviceFind
- XLRDismountBank
- XLREdit
- XLREditData
- XLERase
- XLRGetBankStatus
- XLRGetBaseAddr
- XLRGetBaseRange
- XLRGetChassisType
- XLRGetDeviceInfo
- XLRGetDeviceStatus
- XLRGetDirectory
- XLRGetDriveInfo
- XLRGetErrorMessage
- XLRGetEvents
- XLRGetEventsLength
- XLRGetFIFOLength
- XLRGetLabel
- XLRGetLastError
- XLRGetLength
- XLRGetLengthPages
- XLRGetLengthLowHigh
- XLRGetMode
- XLRGetOption
- XLRGetPartitionInfo
- XLRGetPlayBufferStatus
- XLRGetPlayLength
- XLRGetSystemAddr

- XLRGetUserDir
- XLRGetUserDirLength
- XLRGetVersion
- XLRGetWindowAddr
- XLRMountBank
- XLROpen
- XLRPartitionCreate
- XLRPartitionSelect
- XLRPlayback
- XLRPlayTrigger
- XLRRead
- XLRReadData
- XLRReadFifo
- XLRReadImmed
- XLRReadStatus
- XLRReadToPhy
- XLRRecord
- XLRRecoverData
- XLRReset
- XLRRetrieveEvents
- XLRSelectBank
- XLRSelectChannel
- XLRSelfTest
- XLRSetBankMode
- XLRSetDBMode
- XLRSetDriveStandbyMode
- XLRSetLabel
- XLRSetMode
- XLRSetOption
- XLRSetPlaybackLength
- XLRSetPortClock
- XLRSetReadLimit
- XLRSetUserDir
- XLRSetWriteProtect
- XLRStop
- XLRTruncate
- XLRWrite
- XLRWriteData

FPDP Ports

The FPDP (Front Panel Data Port) external port feature is included on your StreamStor PCI-816XF or PCI-816XF2 controller. FPDP is a 32-bit synchronous data bus that allows data to be transferred at high speeds between devices. Simple and low-cost in its implementation, FPDP supports the necessary flow controls to manage transfers between devices of different speeds. Sustained speeds up to 200Mbytes/sec are supported on the StreamStor FPDP interface.

In reading the following sections on using this feature, it is important to be familiar with the American National Standard for Front Panel Data Port Specifications (ANSI/VITA 17-1998). This manual is intended to clarify StreamStor's operation as it relates to the standard, not to educate one on the standard itself. For additional information about the standard, other FPDP products and manufacturers, and other technical details regarding FPDP, please visit www.fpdp.com.

The StreamStor FPDP interface is designed to meet and exceed the basic capabilities of FPDP as defined in the FPDP ANSI standard. The following sections describe:

- any optional FPDP features StreamStor has implemented;
- any features that StreamStor has implemented as a superset to the standard;
- any known deviations from the ANSI standard;
- any clarifications that might otherwise be left open to interpretation; and
- the API functions necessary to configure an external port.

Interface Electronics

Interface electronics and termination values on StreamStor are those recommended by the ANSI standard, though some signals and terminations can be electronically connected or isolated with crossbar switching devices in order to support electronic reconfiguration.

Data Formats

The FPDP is a multi-drop bus intended to carry either framed or unframed data. StreamStor normally supports only the unframed data mode. The SYNC* (Sync Pulse) signal is driven to an inactive state while StreamStor is a data transmitter on the FPDP bus.

Contact Conduant for more information on using framed data.

PIO Signals

PIO signals are programmable lines for I/O for user-defined functions. These are ancillary signals and are not required for the FPDP function. StreamStor can use these signals to capture external events and mark the location of their occurrence in the data stream. Contact Conduant for more information on using PIO signals.

Connector Position

The location of the top FPDP connector on the StreamStor board is shown in Figure 3.

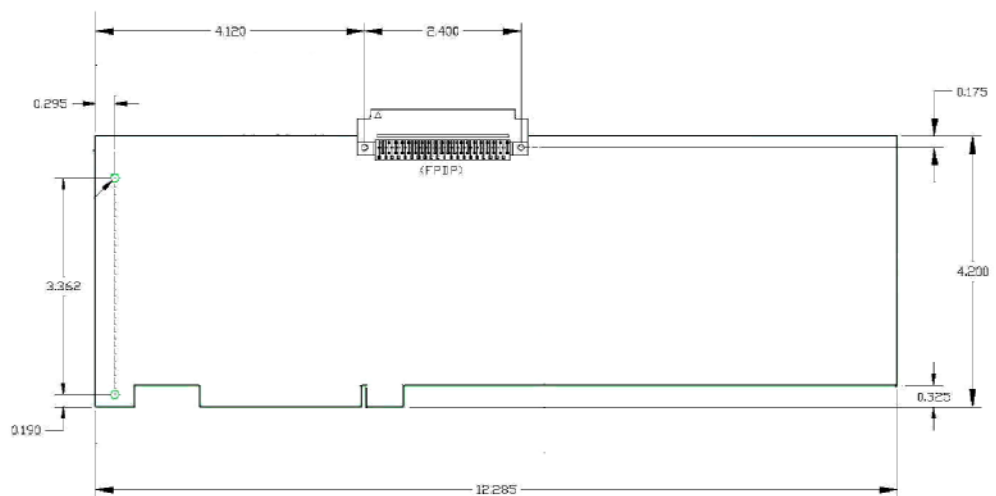

Figure 2 - StreamStor FPDP Connector location

Interface Functions

To ready StreamStor to transfer data using FPDP, the API routine `XLRBindxxxChannel` must be called. The FPDP port's channel number will depend on the board type. (For details on channel numbers, see Table 4). The bind function is called as follows (`xxx` stands for "Input" or "Output" depending on intended usage):

```
XLRBindxxxChannel ( device, channel number );
```

After StreamStor is in external port mode, an API call to `XLRSetDBMode` is used to configure the port. This command allows you to set the mode to one of:

- FPDP Transmit Master (FPDP/TM)
- FPDP Transmit (FPDP/T, StreamStor unique)
- FPDP Receive (FPDP/R)

- FPDP Receive Master (FPDP/RM).
- FPDP Receive Master Clock Master (FPDP/RMCM, StreamStor unique)

See Table 2 for the actual constants to use with this function. In FPDP/T mode, StreamStor drives the FPDP DATA, DVALID* (Data Valid), DIR* (direction), and SYNC* (Sync Pulse) signals but uses the FPDP clock that is driven to the FPDP bus by some other source. In this mode, StreamStor does not provide any termination for signals other than DATA. To use this mode properly, StreamStor should NOT be positioned at either end of the FPDP bus. Note also that the maximum useable frequency in this mode will decay more rapidly as the cumulative distance from the clock source to the data source to the data destination increases.

NOTE: *StreamStor always provides series termination on the DATA signals as described in Permission 6.4.1 of the specification.*

In FPDP/RMCM mode, StreamStor acts as a Receive Master, excepting that StreamStor also drives the FPDP clock signals on the FPDP bus. In addition, StreamStor terminates the clock signals (PSTROBE, PSTROBE*, and STROB) as would a traditional FPDP/TM while terminating the remaining signals as would a FPDP/RM. To use this mode StreamStor should be physically positioned at an end of the FPDP bus. Note also that the maximum useable frequency in this mode will decay more rapidly as the cumulative distance from the clock source to the data source to the data destination increases.

When configuring StreamStor as a recorder, it may be desirable to prevent a transmitter from sending data until the StreamStor recording function is fully enabled. XLRSetDBMode can be used to assert the FPDP NRDY* (Not Ready) signal when StreamStor is activated as a FPDP receiver. NRDY* will remain asserted until the StreamStor data recording process is ready to proceed. An example of this is:

```
XLRSetDBMode(device, SS_FPDP_RECVMaster, SS_OPT_FPDPNRASSERT );
```

PSTROBE/PSTROBE* and STROB Signals

When in FPDP/TM and FPDP/RMCM modes, StreamStor will drive and terminate both the differential clock pair of PSTROBE, PSTROBE* (\pm PECL Data Strobe) and the single-ended STROB (Data Strobe) TTL clock. When in any other mode, the user will select which of the two FPDP clock sources StreamStor should use from the FPDP bus. The clock can be selected by calling XLRSetDBMode with the desired clock option. For example, to enable the data strobe clock (TTL):

```
XLRSetDBMode( device, SS_FPDP_RECV, SS_OPT_FPDPSTROB );
```

Refer to the FPDP ANSI standard for recommendations and observations about the use of these signals.

Operating Frequency Range

In either FPDP/TM or FPDP/RMCM mode, StreamStor can be programmed to synthesize a bus clock in the range from 6 to 50MHz. StreamStor can operate from FPDP clocks supplied by other sources at frequencies down to DC. Note, however, that the ANSI specification limits the clock to 20MHz if a receiver is using the STROB (Data Strobe) clock. To program the clock, use the API function `XLRSetPortClock`. By default, the clock frequency is 8MHZ.

Programming

The FPDP port is designed for maximum flexibility and can be configured to run as a receiver or transmitter at various clock frequencies. The `XLRSetDBMode` function provided by the StreamStor API is used to set most of these parameters and options (see SDK user manual). Table 2 lists the supported modes for this daughter board. Note that the board must be in a compatible mode for the StreamStor operation being requested (i.e. a receive mode `XLRRecord`, transmit mode for `XLRRead`, etc.). The user is responsible for configuring the FPDP bus such that termination is applied only at each end.

TABLE 2 – FPDP Modes supported	
Mode	Description
SS_FPDP_RECVMASTER	Receive data, receive master termination applied.
SS_FPDP_RECV	Receive data
SS_FPDP_XMIT	Transmit data, no clock output (not defined by FPDP specification)
SS_FPDP_XMITMASTER	Transmit data and clocks, transmit master termination applied.
SS_FPDP_RECVMASTER_CLOCKS	Receive data and transmit clocks, receive master termination applied (not defined by FPDP spec.)

Table 3 details the supported options for the FPDP ports. These options may be combined using a Boolean “or” operation before passing them into the XLRSetDBMode function.

TABLE 3 – FPDP Options	
Option	Description
0	Reset all options to default
SS_OPT_EVENT_SYNC_RISE	Capture event on rising edge of SYNC
SS_OPT_EVENT_SYNC_FALL	Capture event on falling edge of SYNC
SS_OPT_EVENT_PIO1_RISE	Capture event on rising edge of PIO1
SS_OPT_EVENT_PIO1_FALL	Capture event on falling edge of PIO1
SS_OPT_EVENT_PIO2_RISE	Capture event on rising edge of PIO2
SS_OPT_EVENT_PIO2_FALL	Capture event on falling edge of PIO2
SS_OPT_EVENT_FULLBLOCK	Block further capture of events if event FIFO full
SS_OPT_FPDPEVENTLOG	Enable event logging
SS_OPT_FPDPNOPLL	Disable PLL on clock for low frequency operations.
SS_OPT_FPDPNRASSERT	Receiver will assert “Not Ready” signal until recording starts
SS_OPT_FPD PSTROBE	Enable TTL clock (PECL is default)
SS_OPT_FPDPSYNC	Wait for sync before recording
SS_OPT_FPDPSYNCARM	Configures StreamStor and readies it for recording, but data will not be recorded until XLRArmFPDP is called and an FPDP SYNC* pulse is received.
SS_OPT_FPDPSINGLEFRAME	Single frame data format while recording/playback. When set for recording, the FPDP port on StreamStor will wait for an FPDP SYNC* pulse before any data on the FPDP interface is recorded. All valid data prior to and during the first cycle of the SYNC* pulse will be discarded. When set for playback operation, StreamStor will generate a single cycle FPDP SYNC* pulse a few clocks prior to asserting DVALID* and transmitting data.

The StreamStor system can be configured in various ways to record or playback from the FPDP ports or the PCI bus. These modes of operation are configured using the `XLRSetMode` function (i.e. `SS_MODE_SINGLE_CHANNEL`). Each of the possible input or output ports is considered a channel and must be bound into the StreamStor controller before recording or playback will occur from that port. By default, the PCI bus is bound as both the input and output port in single channel mode. Most applications will utilize the single channel mode with a single input and output channel defined. The API functions `XLRBindInputChannel` and `XLRBindOutputChannel` must be called to define an input and output port if other than the PCI bus.

Table 4 defines the constants to use to select the appropriate channel for your application.

TABLE 4 – Channel definition	
Port Description	Channel constant
PCI	0
FPDP Top (upper edge of PCI board)	30
FPDP Front (bracket end of PCI board)	31

The FPDP ports also provide programmable clock speeds for those modes that drive a clock onto the FPDP bus (SS_FPDP_XMITMASTER, SS_FPDP_RECVM_CLOCKS). Table 5 lists the available clock speed settings that can be set using the function XLRSetPortClock.

TABLE 5 – Clock settings	
Actual Clock speed	Clock Constant
6 MHz	SS_PORTCLOCK_6MHZ
8 MHz	SS_PORTCLOCK_8MHZ
10 MHz	SS_PORTCLOCK_10MHZ
11.4 MHz	SS_PORTCLOCK_11MHZ
13.33 MHz	SS_PORTCLOCK_13MHZ
16 MHz	SS_PORTCLOCK_16MHZ
20 MHz	SS_PORTCLOCK_20MHZ
26.56 MHz	SS_PORTCLOCK_25MHZ
26.66 MHz	SS_PORTCLOCK_26MHZ
32 MHz	SS_PORTCLOCK_32MHZ
40 MHz	SS_PORTCLOCK_40MHZ
50 MHz	SS_PORTCLOCK_50MHZ
50.04 MHz	SS_PORTCLOCK_51MHZ

Technical Support

Conduant wants to be sure that your StreamStor system works correctly and stays working correctly. In the event, however, that you are unable to get your new system to work properly, or if a working system ceases to function, we will do all that we can to get your system back online.

Solving the problem is largely a matter of data collection and steps that must be taken one at a time. In order for us to better serve you, we ask that you take the time to perform the following steps prior to calling us. This way, you can provide us with the most meaningful information possible that will help us solve the problem.

Is the problem one that obviously requires replacement parts due to physical damage to the system? If yes, then please gather the information described below and report the problem to tech support, by phone or through the Conduant web site.

Have you confirmed that no cabling has been inadvertently disconnected or damaged while working around the equipment?

Is the StreamStor card properly seated in the PCI slot?

Do all the systems have good power connections and voltages?

Does the confidence test `sscfg.exe` (on Windows) or `ssopen/sstest` (on Linux) run OK?

Has the software installation been corrupted? Try re-installing software.

Have you checked the Conduant web site for technical bulletins?

Have you recently installed a new Linux kernel or compiler or a new Windows Service Pack?

If the above steps did not resolve the problem, then please initiate a trouble ticket on the support section of the Conduant website at www.conduant.com. Please provide as much information about your system and the problem as possible. We will do all that we can to resolve the problem as quickly as possible.

Contacting Technical Support

E-mail: support@conduant.com

Web: www.conduant.com

Mail: Conduant Corporation
Technical Support
1501 South Sunset Street, Suite C
Longmont, CO 80501