

The StreamStor Architecture

StreamStor is a completely integrated subsystem which manages all aspects of the data streaming operation without intervention by a host computer. This unique architecture achieves hardware speeds with sustained, raw (uncompressed) data transfer rates of up to 200 Mbytes/Sec per controller and storage capacities scalable to several terabytes.

A powerful hardware engine manages the data flow to and from the disk drives and facilitates a direct data transfer from the data source. A PowerPC™ processor is used to manage the data transfer and provide an intelligent control interface to the host computer. Standard ATA hard drives are utilized providing the best price/performance for real-time data streaming applications.

Dynamic Storage Management

Optimized for real-time (sustained) recording & playback, StreamStor eliminates several bottlenecks common to RAIDS and other conventional storage systems. StreamStor controllers dynamically configure to the number of hard drives installed, up to 16 on some models, at startup. During the recording operation, StreamStor dynamically allocates the next available drive - resulting in ZERO data loss, ZERO fragmentation, and no stream delays.

Fault Tolerance & Scalability

Use master/slave mirroring or multiple StreamStor controllers daisy chained together for full data redundancy. Multi-bus configurations can be utilized when the data stream is split external to StreamStor for data rates well beyond 200 Mbytes/Sec.

Open Platform Support

StreamStor controllers are available with PCI, CompactPCI, ChannelLink and FPDP interfaces. All models provide support for Windows and Linux environments. Limited VxWorks support is also available. The programming API is compatible with major programming environments including C++ and Visual Basic. StreamStor can be paired with most PCI and CompactPCI data acquisition boards provided they have DMA (Direct Memory Addressing) hardware and bus mastering capability. This is true of most performance sensitive digital hardware today.

Packaging Options

Our Big River product line offers portable and rack mount enclosures in a variety of high performance configurations. Visit our web site or contact Conduant for details.

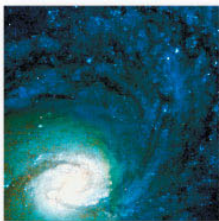

StreamStor facilitates a direct data transfer from the data source

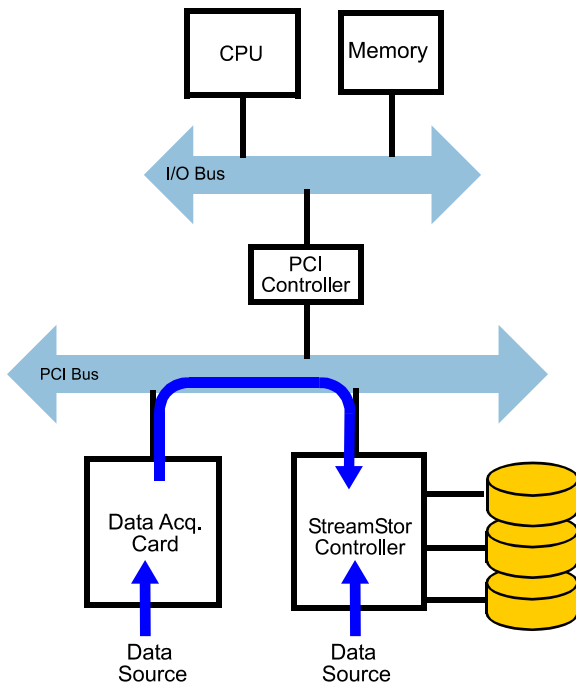

The Problem: General purpose storage is not optimized for sustained recording and playback

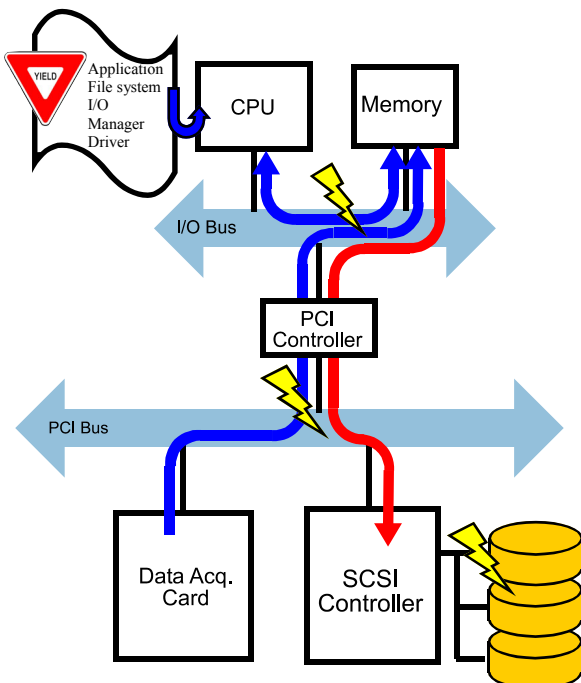

The Problem

Trying to stream data to standard computer storage peripherals from a PCI capture card means the data must first be written to system memory and then copied back out to the storage system under control of the operating system. Because the data must make two trips on the PCI bus, the available PCI bandwidth is reduced by 50%. Copying data in and out of system memory creates a conflict with the host CPU which is also trying to read and write from system memory.

Solution!

The *StreamStor* controllers utilize direct data transfers from the data source or acquisition board to eliminate a trip in and out of system memory and use of host CPU resources.

The Problem

A system storage peripheral is controlled by several layers of operating system software including the application, file system, I/O manager and driver software layers. Any of these processes can be interrupted by other host activity delaying the movement of data to the storage system. System load and performance has a direct impact on the performance of the data storage system.

Solution!

StreamStor controllers require no interaction with host software while streaming data to or from disk storage. The streaming process is entirely managed by a dedicated onboard PowerPC processor.

The Problem

Host operating systems maintain the integrity of the file directory on disk(s) for traditional SCSI, RAID and system disks. Directory updates interrupt the data flow and cause actuator (head) movement in the disk drive(s) seriously impacting sustainable performance.

Solution!

StreamStor controllers maintain their own directory and require no interaction with host software while recording data. Directory information is dynamically maintained and updated to the disk system after data streaming is completed.

The Problem

When storing data to a disk system, the operating system may need to scatter the data blocks to various locations on the disk where there is free space. This "fragmentation" causes serious performance penalties due to the required movement of the mechanical actuator.

Solution!

StreamStor controllers are designed to ALWAYS write sequentially to the disk drives. By eliminating fragmentation, *StreamStor* is able to maximize the performance of each individual disk drive.

The Problem

Disk drive errors or delays lead to interrupted recording or lost data when capturing sustained, real-time data streams.

Solution!

StreamStor will dynamically redirect data flow to alternate drives to compensate for disk drive delays or errors during recording.

The high-speed disk recording and playback experts!